

# Bucker Up Channels

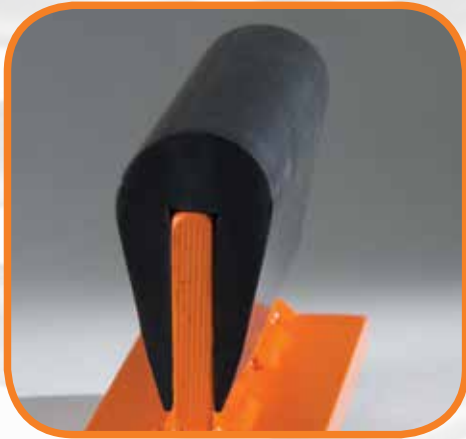

**HOYT**  
WIRE CLOTH

Three **Great** Choices.

Lumsden Corporation  
P.O. Box 4647 • Lancaster, PA 17604  
(717) 394-6871 • Fax: (717) 394-1640

The **Shape**  
of things to come™

For more information, visit [www.HOYTWireCloth.com](http://www.HOYTWireCloth.com)

# HOYT 3/8" Polyurethane Bucker Up Channel

The Crown is both high (5/8") and wide (1 1/8") to provide maximum support for the screen media.

- Leg length is 1" to assure that the channel does not need to be secured by tape or wire and will not roll off the bucker up bar under harsh conditions
- Legs are tapered slightly inward to aid in gripping the bucker up bar to prevent rolling
- Material hardness ("durometer") is specially formulated for maximum screen media support while maintaining maximum wear life
- Lasts 5x longer than the best rubber bucker up channel
- Conveniently shipped in boxed 24' rolls
- Shipped immediately from Hoyt stock



## What makes the difference?

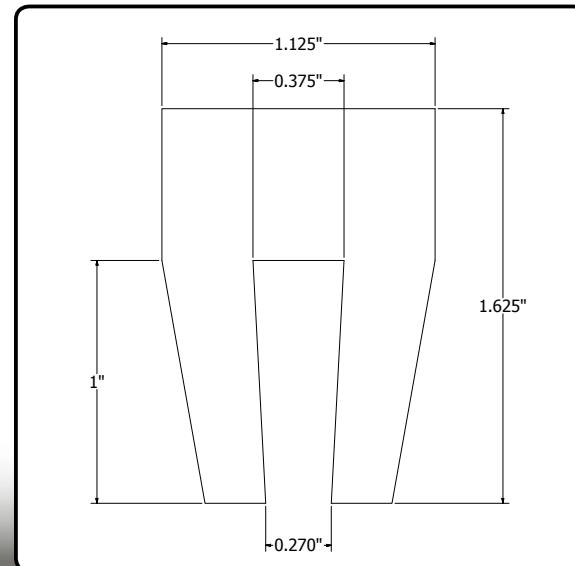

# HOYT 3/8" High Grip Rubber Bucker Up Channel

The Crown is both high (1/2") and wide (1 1/16") to provide maximum support for the screen media.

- Inside corners are relieved to minimize the chance of splitting under heavy loads
- Legs are tapered slightly inward to aid in gripping the bucker up bar to prevent rolling
- Material hardness (65 "durometer") is specially formulated for maximum screen media support while maintaining maximum wear life
- Made of natural rubber, not recycled materials
- Conveniently shipped in 75' cartons
- Shipped immediately from Hoyt stock
- Also available in 1/4", 1/2" and 3/4"\* sizes  
\*packaged in 50' cartons



## What makes the difference?

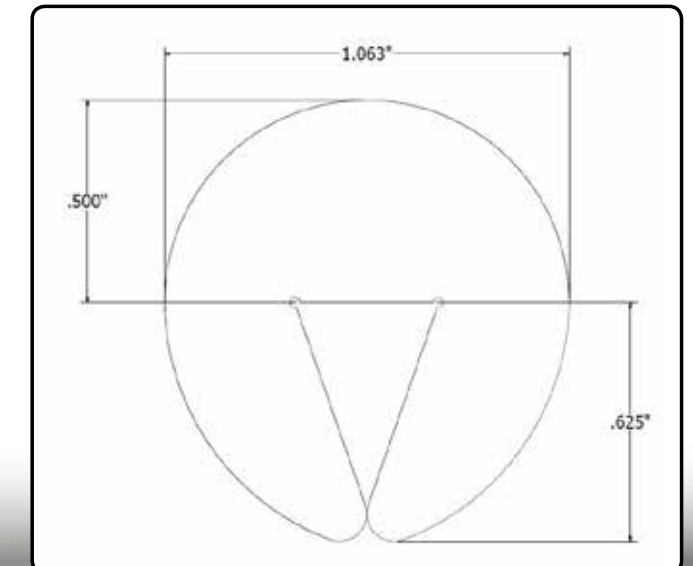

# HOYT 3/8" Long Leg Rubber Bucker Up Channel

The Crown is high (5/8") and wide (1 1/4") to provide maximum support for the screen media.

- Leg length is 1 7/16" to assure that the channel does not need to be secured by tape or wire and will not roll off the bucker up bar under harsh conditions
- Legs are tapered slightly inward to aid in gripping the bucker up bar to prevent rolling
- Material hardness (65 "durometer") is specially formulated for maximum screen media support while maintaining maximum wear life
- Outstanding for scalping, primary or other high impact screen applications
- Conveniently shipped in 50' cartons
- Shipped immediately from Hoyt stock

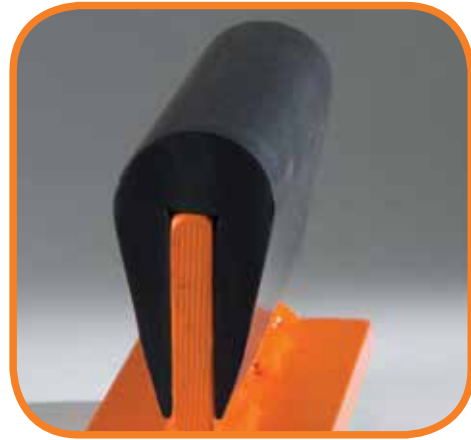

## What makes the difference?

